

A ABEL

WEIGH LORRY SYSTEMS





The present design of the Abel WEIGH LORRY SYSTEM has over twenty years of on-the-job experience built into its design. These electrically controlled units can either be controlled from a catwalk along side of the weigh lorry or from a remote location. Ticket printers are also available if required.

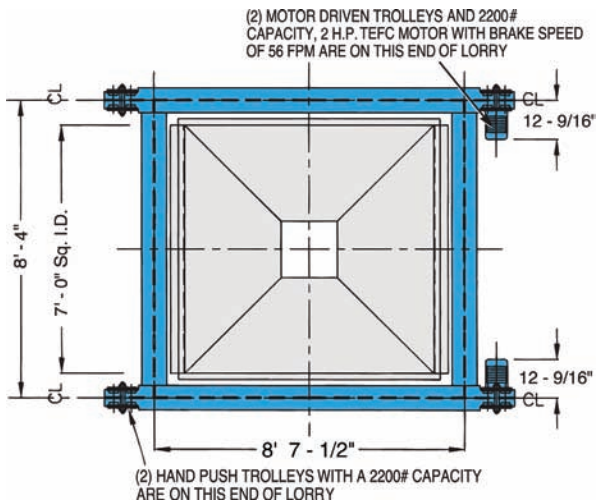

WEIGH LORRY PLAN VIEW

WEIGH LORRY END VIEW

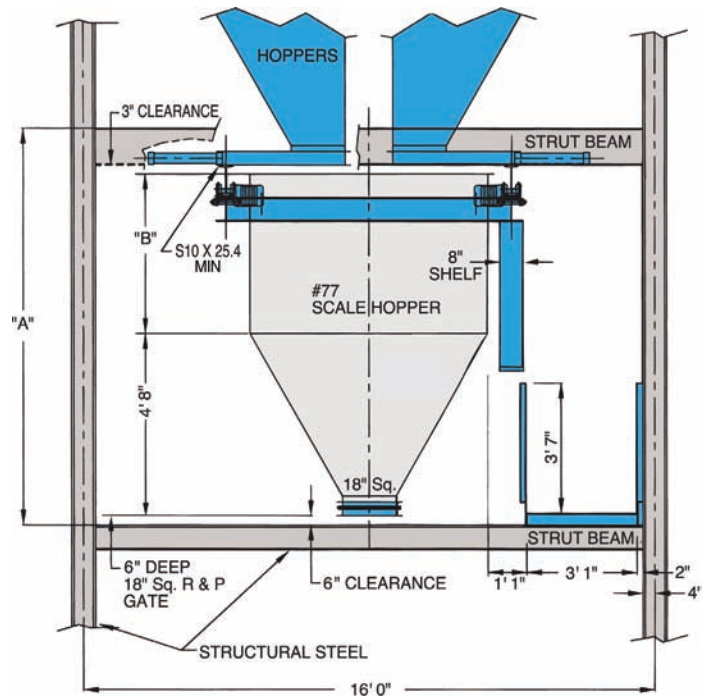

WEIGH LORRY SIDE VIEW

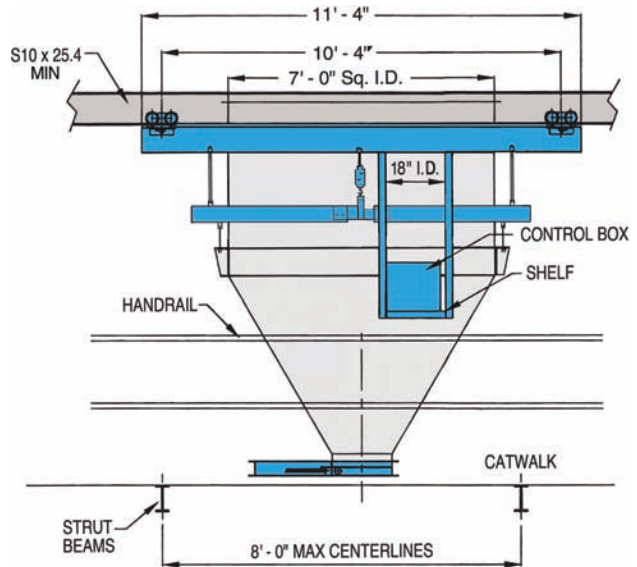

SPECIFICATIONS

MODEL NO.	SIZE	CU. FT.	WT. PER CU.FT.	TONS	TRAVEL SPEED	H.P.	A	B
77-3T	7'x7'	186	35#	3.2	56 F.P.M.	2	11'-0"	3'-10"
77-4T	7'x7'	235	35#	4.1	56 F.P.M.	2	12'-0"	4'-10"
77-5T	7'x7'	288	35#	5.0	56 F.P.M.	2	13'-0"	5'-10"



ABEL MANUFACTURING COMPANY, INC.

1100 NORTH MAYFLOWER DRIVE ■ P.O. BOX 757 ■ APPLETON, WI 54912 ■ U.S.A.

TEL: 920-734-4443
 FAX: 920-734-1084
 E MAIL: sales@abelusa.com
 WEB: www.abelusa.com